

Fastenal Product Standard: FNL.SQHSS.CP.P

Square Head Set Screws, Cup Point, Plain Finish

The information below lists the required dimensional, chemical and physical characteristics of the fasteners in this purchase order. If the order received does not meet these requirements, it may result in a supplier corrective action request, which could jeopardize your status as an approved vendor. Unless otherwise specified, all referenced consensus standards must be adhered to in their entirety.

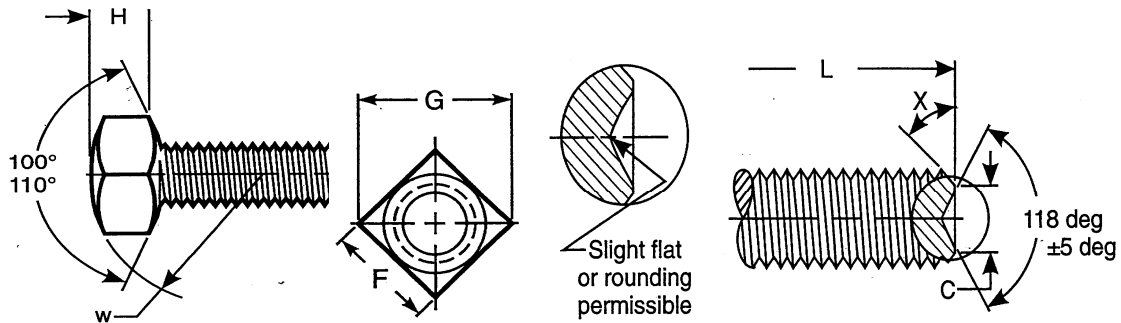

Size	F		G		H		C	
	Width Across Flats		Width Across Corners		Head Height		Cup Point Diameter	
	Max.	Min.	Max.	Min.	Max.	Min.	Max.	Min.
10	.188	.180	.265	.247	.148	.134	.102	.088
1/4	.250	.241	.354	.331	.196	.178	.132	.118
5/16	.312	.302	.442	.415	.245	.224	.172	.156
3/8	.375	.362	.530	.497	.293	.270	.212	.194
7/16	.438	.423	.619	.581	.341	.315	.252	.232
1/2	.500	.484	.707	.665	.389	.361	.291	.270
5/8	.625	.606	.884	.833	.485	.452	.371	.347
3/4	.750	.729	1.060	1.001	.582	.544	.450	.425
7/8	.875	.852	1.237	1.170	.678	.635	.530	.502
1	1.000	.974	1.414	1.337	.774	.726	.609	.579
1 1/8	1.125	1.096	1.591	1.505	.870	.817	.689	.655
1 1/4	1.250	1.219	1.768	1.674	.966	.908	.767	.733
1 3/8	1.375	1.342	1.945	1.843	1.063	1.000	.848	.808
1 1/2	1.500	1.464	2.121	2.010	1.159	1.091	.926	.886

Specification Requirements:

- Dimensions: ASME B18.6.2.
- Point Style: Cup.
- Material & Mechanical Properties: Case Hardened Steel per ASME B18.6.2.
- Thread requirements: ANSI B1.1, UNC and UNF, Class 2A.
- Finish: Light protective oil