

## Fastenal Product Standard: FNL.M.SHCS.A2-70

### Socket Head Cap Screws, Metric, A2-70 Stainless Steel

The information below lists the required dimensional, chemical and physical characteristics of the products in this purchase order. If the order received does not meet these requirements, it may result in a supplier corrective action request, which could jeopardize your status as an approved vendor. Unless otherwise specified, all referenced consensus standards must be adhered to in their entirety.

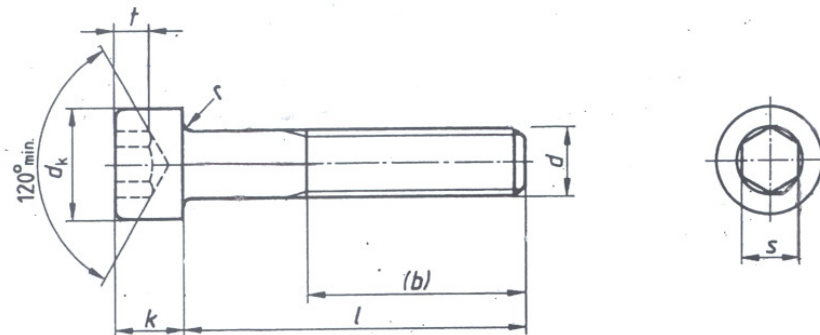

Nominal Size (mm)	d1		d2		k		s			t
	Body Dia.		Head Dia.		Head Height		Socket Size			Key Engagement
	Max.	Min.	Max.	Min.	Max.	Min.	Nom.	Max.	Min.	Min.
1.6	1.60	1.46	3.14	2.86	1.60	1.46	1.5	1.56	1.52	0.7
2	2.00	1.86	3.98	3.62	2.00	1.86	1.5	1.56	1.52	1
2.5	2.50	2.36	4.68	4.32	2.50	2.36	2	2.06	2.02	1.1
3	3.00	2.86	5.68	5.32	3.00	2.86	2.5	2.58	2.52	1.3
4	4.00	3.82	7.22	6.78	4.00	3.82	3	3.08	3.02	2
5	5.00	4.82	8.72	8.28	5.00	4.82	4	4.095	4.02	2.5
6	6.00	5.82	10.22	9.78	6.00	5.70	5	5.14	5.02	3
8	8.00	7.78	13.27	12.73	8.00	7.64	6	6.14	6.02	4
10	10.00	9.78	16.27	15.73	10.00	9.64	8	8.175	8.025	5
12	12.00	11.73	18.27	17.73	12.00	11.57	10	10.175	10.025	6
14	14.00	13.73	21.33	20.67	14.00	13.57	12	12.212	12.032	7
16	16.00	15.73	24.33	23.67	16.00	15.57	14	14.212	14.032	8
18	18.00	17.73	27.33	26.67	18.00	17.57	14	14.212	14.032	9
20	20.00	19.67	30.33	29.67	20.00	19.48	17	17.23	17.05	10
22	22.00	21.67	33.39	32.61	22.00	21.48	17	17.23	17.05	11
24	24.00	23.67	36.39	35.61	24.00	23.48	19	19.275	19.065	12
27	27.00	26.67	40.39	39.61	27.00	26.48	19	19.275	19.065	13.5
30	30.00	29.67	45.39	44.61	30.00	29.48	22	22.275	22.065	15.5
33	33.00	32.61	50.39	49.61	33.00	32.38	24	24.275	24.065	18
36	36.00	35.61	54.46	53.54	36.00	35.38	27	27.275	27.065	19
42	42.00	41.61	63.46	62.54	42.00	41.38	32	32.33	32.08	24

#### Specification Requirements:

- Dimensions: DIN 912.
- Threads: 6g
- Material & Mechanical Properties: A2-70 Stainless Steel per ISO 3506 part 1
- Finish: Per ASTM A380
- Material Test Reports: The MTR must have documented lot traceability, including full chemical and mechanical figures, to the specification(s) above.